

B41 4-Channel RF Relays

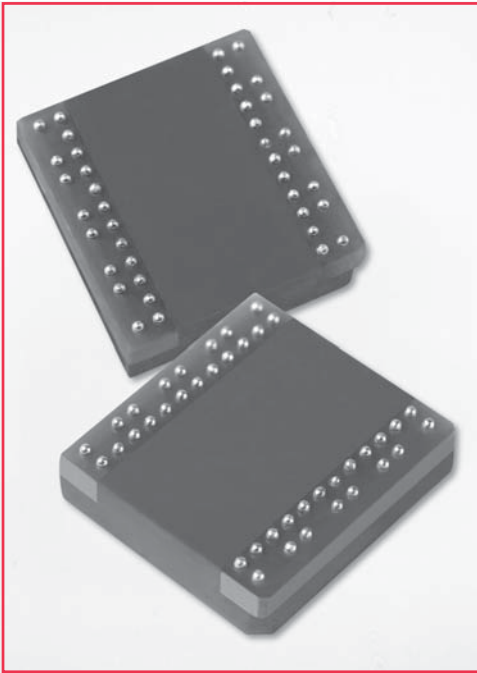

Ball Grid Array 4-Channel Relays

The B41 is four independent form A channels in one planar quad package. Coto's Ball Grid Array (BGA) construction offers a breakthrough in reed relay performance. This patented technology¹ allows for shorter RF paths in a controlled 50Ω environment to minimize signal attenuation. The designer is now able to switch or pass signals with wider bandwidth and faster rise time than alternative technologies. This is particularly important in Mixed Signal IC testers. This 4-in-one BGA packaging allows relays to be integrated easily on boards designed for surface mount processing.

Series Features

- ◆ Planar BGA Surface Mount
- ◆ Ability to pass GHz signals
- ◆ Rise time < 45pSec
- ◆ ~50Ω Characteristic Impedance
- ◆ Low Capacitance
- ◆ Patented Design¹

Applications

- ◆ IC Testers
- ◆ In-Line Relay Testers
- ◆ Memory Testers
- ◆ Mixed Signal Testers
- ◆ High Bandpass Applications

Top View

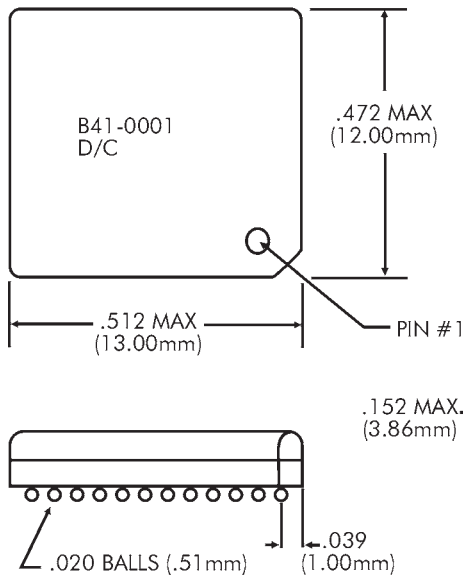

Top View Ball Pattern

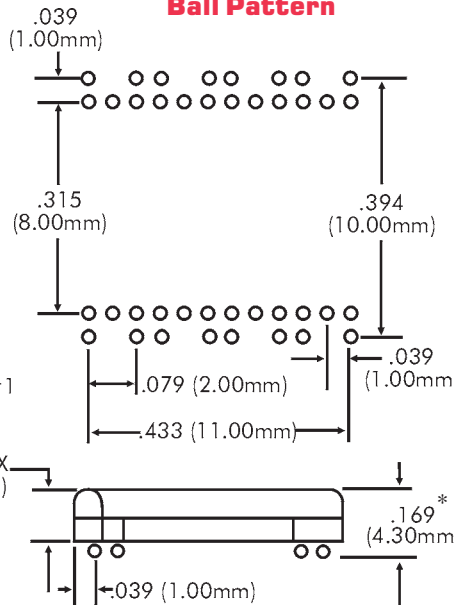

Top View Schematic

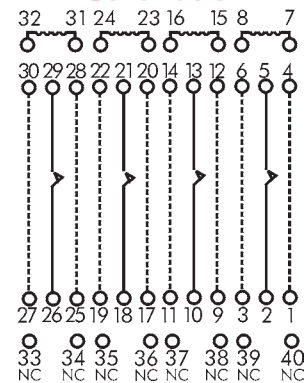

Dimensions in Inches (mm)
METRIC DIMENSIONS GOVERN
General Dimensional Tolerance:
± .006 (0.15)

*Dimensions shown are before soldering.

B41 RECEIVER BOARD PAD LAYOUT

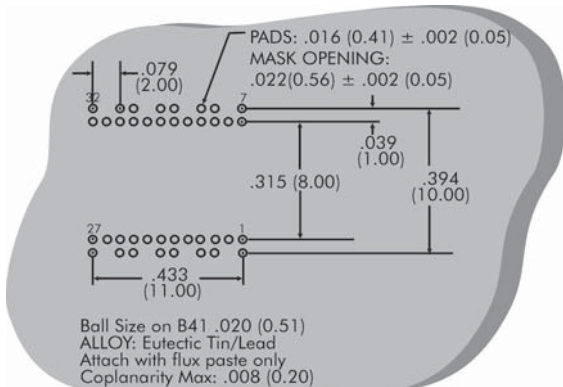

Ordering Information

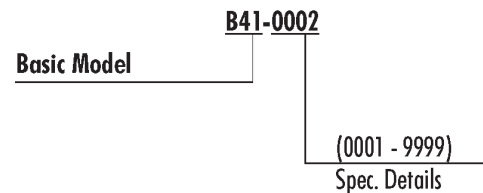

Notes:

¹ Protected by one or more of the following US Patents: 6025768, 6052045, 6294971, 6683518, RE38381 and other foreign patents.

B41 4-Channel RF Relays

Test Parameters	Conditions ^{1,2}	Min	B41		Units
			Typ	Max	
Coil Resistance		49.5	55.0	60.5	Ω
Nominal Voltage	3.3V Coil		3.3	4.0	Volts DC
Must Operate Voltage				2.4	Volts DC
Must Release Voltage	B41-0002	0.4			Volts DC
Coil Resistance		144.0	160.0	176.0	Ω
Nominal Voltage	5V Coil		5.0	6.0	Volts DC
Must Operate Voltage				3.8	Volts DC
Must Release Voltage	B41-0001	0.4			Volts DC
Switching Voltage	Max DC/Peak AC			125	Volts
Switching Current				0.40	Amps
Carry Current (Continuous)	Switch and Shield			0.5	Amps
Contact Rating (Resistive Load)	Resistive Load			3.0	Watts
Life Expectancy	Signal Switching ³		1000		x 10 ⁹ Ops
	Resistive Load ³		1		x 10 ⁶ Ops
	Other Load Conditions ³				Consult Factory
Static Contact Resistance (initial)	0.05VDC / 10mA			0.125	Ω
Dynamic Contact Resistance (initial)	0.5V / 10mA 100 Hz, 1.5 mSec			0.150	Ω
Insulation Res	All Isolated Pins	10 ¹⁰	10 ¹²		Ω
Capacitance	Across Contacts		0.2		pF
Capacitance	Open Contact to Coil		0.3		pF
Capacitance	Closed Contact to Coil		0.5		pF
Dielectric Strength	Across Contacts		150		V (DC/Pk AC)
	Contact to Coil		1000		V (DC/Pk AC)
	Contact To Shield		1000		V (DC/Pk AC)
	Between Contacts of Adjacent Channels		1000		V (DC/Pk AC)
Operate Time (including bounce)	Nominal Voltage coil drive @ 30 Hz,		100	200	μSec
Release Time (Si diode damped)	square wave		30	50	μSec
RF Insertion Loss ⁴	-3 dB roll-off frequency	8.0			GHz
RF Inter-Channel Isolation	Signal isolation between adjacent closed channels, 1GHz test signal	40.0			dB
Signal Rise Time (10% - 90%)				45	pSec
Magnetic Interaction ⁵	Between adjacent channels			16	%

NOTES:

¹All parameters specified per EIA/NARM standards for dry reed relays, # RS-421 and RS-436, if a suitable parametric standard exists.

²Unless otherwise noted, all parameters are specified at 25°C and 40% RH.

³Life expectancies based on characteristic life (63.2% failure) calculated from the 2-parameter Weibull distribution. Contact resistance >2.0Ω defines end of life.

⁴Frequency at which the difference between output and input signal amplitude exceeds -3dB.

⁵Maximum increase in operate voltage for any channel when all channel coils are driven at nominal coil voltage and with the same drive polarity.

ENVIRONMENTAL RATINGS:

Storage Temperature: -35°C to +100°C.

Operating Temperature: -20°C to +85°C.

Vibration: sinusoidal vibration with an amplitude of 10G over a 10Hz to 2000Hz frequency range shall neither cause a closed channel activated at the nominal coil voltage to open, nor an open channel to close. Max Soldering Temperature: 226°C (438°F) max for 1 minute dwell time. Temperature measured at a relay ball termination.

Moisture sensitive component. Handle as J-STD-020B level 5a.